



DI GROOVED FITTINGS-ANSI CLASS 150 GROOVED FLANGE

Type: GFA Doc No:DS-400-GFA-01-E

1.0 PRODUCT OVERVIEW

The grooved flange is used for the conversion of the grooved pipe connection to the flange connection. It is a special connection fitting used when the groove connection is connected to the American standard Class 150 flange.



Dimensions:

2"(DN50)–24"(DN600)

Design Standard:

ISO6182, ASME B16.5, GB 5135.11

Connection Standard:

ASME B36.10, ASTM A53-A53M, ISO 4200

Working Pressure:

American standard Class150

Application:

Grooved flange is suitable for medium and low pressure pipeline systems with nominal pressure CLASS 150, nominal size DN50-DN600, temperature range of -20 °C-+180°C, which are widely applied in water supply and drainage, fire-fighting, air conditioning, etc.

Pipe Material:

Welded and seamless rolled steel pipes according to ASME B36.10, ASTM A53-A53M, ISO 4200.

Surface Treatment:



- Electrophoretic painting
- Epoxy power painting
- Hot-dip galvanizing
- Black
- Others would be available upon clients' detailed request

2.0 APPROVALS

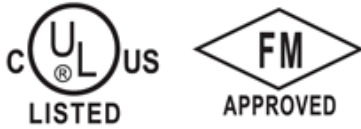

3.0 SPECIFICATIONS

ASTM A536, Ductile iron according to 65-45-12. The nodularity is more than 90%, ensuring excellent physical and mechanical properties.

4.0 DIMENSIONS AND PERFORMANCE

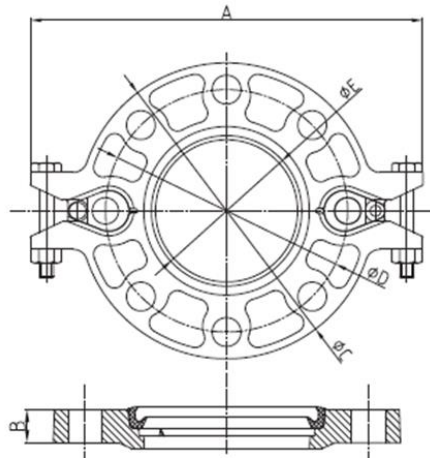



Nominal Size	Pipe O.D	Working Pressure	Dimensions					Bolt/Nut	
			A	B	C	D	E	No.-SIZE	
DN/in	mm/in	PSI/MPa	mm/in	mm/in	mm/in	mm/in	mm/in	mm	
50 2	60.3 2.375	300 2.07	206 8.11	19 0.75	152 5.98	121 4.76	57.5 2.26	2-M10X50	4-5/8
65 2½	73 2.875	300 2.07	230 9.05	19 0.75	178 7	140 5.51	69.8 2.74	2-M10X50	4-5/8
65 2½	76.1 3	300 2.07	230 9.05	19 0.75	178 7	140 5.51	72.7 2.86	2-M10X50	4-5/8
80 3	88.9 3.5	300 2.07	246 9.68	19 0.75	191 7.52	152 5.98	85.5 3.37	2-M10X50	4-5/8
100 4	114.3 4.5	300 2.07	280 11.02	19 0.75	229 9	191 7.52	110.5 4.35	2-M12X55	8-5/8
125 5	141.3 5.563	300 2.07	320 12.6	22 0.87	254 10	216 8.5	137.4 5.41	2-M12X65	8-3/4
150 6	168.3 6.625	300 2.07	346 13.62	24 0.94	280 11	241.3 9.5	164.3 6.47	2-M12X65	8-3/4
200 8	219.1 8.625	300 2.07	414.3 16.31	30 1.18	341.4 13.44	298.5 11.75	214.9 8.46	2-3/8X70 2-M10X70	8-3/4
250 10	273 10.75	300 2.07	481.2 18.94	30.3 1.19	405.6 15.97	361.95 14.25	268.9 10.59	2-3/8X70 2-M10X70	12-7/8
300 12	323.9 12.75	300 2.07	553.3 21.78	30.4 1.2	482.6 19	431.8 17	318.9 12.56	2-3/8X70 2-M10X70	12-7/8
350 14	355.6 14	300 2.07	590 23.22	37 1.44	535 21	476.3 18.75	350.6 13.8	—	12-1
400 16	406.4 16	300 2.07	650 25.59	37 1.44	595 23.5	539.8 21.25	401.5 15.81	—	16-1
450 18	457.2 18	300 2.07	690 27.17	40 1.56	635 25.8	577.8 22.75	452.2 17.8	—	16-11/8
500 20	508 20	300 2.07	765 30.12	43 1.69	700 27.5	635 25	503 19.8	—	20-11/8
600 24	609.6 24	300 2.07	875 34.45	49 1.94	815 32	749.3 29.5	601.6 23.69	—	20-11/4

5.0 REFERENCE MATERIALS

Approved certification for Grooved Fittings and Couplings

I-JM-Grooved fitting: Installation Instructions for grooved fittings and couplings