



DI GROOVED MECHANICAL TEE-GROOVED OUTLET

Type: MT2 Doc No:DS-400-MT2-01-E

1.0 PRODUCT OVERVIEW

Grooved outlet mechanical tee is a saddle-shaped joint for connecting one side of a pipe in the middle of a straight pipe, the branch pipe is a grooved connection.



Dimensions:

1"(DN25)–10"(DN250)

Design Standard:

ISO6182, AWWA C606, GB 5135.11

Connection Standard:

ASME B36.10, ASTM A53-A53M, ISO 4200

Working Pressure:

175PSI-300PSI

Application:

Grooved outlet mechanical tee is suitable for medium and low pressure pipeline systems with nominal pressure 175-300 PSI, nominal size DN25-DN250, temperature range of - 20 °C--+180°C, which are widely applied in water supply and drainage, fire-fighting, air conditioning, etc.

Pipe Material:

Welded and seamless rolled steel pipes according to ASME B36.10, ASTM A53-A53M, ISO 4200, GB/T 21835

Surface Treatment:



- Electrophoretic painting
- Epoxy power painting
- Hot-dip galvanizing
- Black
- Others would be available upon clients' detailed request

2.0 APPROVALS



3.0 SPECIFICATIONS

Housing:

ASTM A536, Ductile iron 65-45-12

Gasket:

1、EPDM Gasket, code E:

Temperature: $-34^{\circ}\text{C} \sim +110^{\circ}\text{C}$ ($-30 \sim +230^{\circ}\text{F}$) ;

Applicable media: water, gas, diluted acid (base), and other chemicals (excluding hydrocarbons)

Note: Strictly prohibit the use of oil and hydrocarbons.

2、NBR, code D:

Temperature: $-29^{\circ}\text{C} \sim +82^{\circ}\text{C}$ ($-20 \sim +180^{\circ}\text{F}$) ;

Applicable media: Petroleum products, vegetable oils, mineral oils, etc.

Note: strictly prohibit use with high temperature substances.

3、Silicone Rubber, code S:

Temperature: $-40^{\circ}\text{C} \sim +177^{\circ}\text{C}$ ($-40 \sim +350^{\circ}\text{F}$)

Applicable media: High temperature and dry air and some high temperature chemicals, drinking water and so on.

4、Chloroprene Rubber, code LD:

Temperature: $-32^{\circ}\text{C} \sim +82^{\circ}\text{C}$ ($-26 \sim +180^{\circ}\text{F}$)

Applicable media: sea water

5、Fluororubber, code F:

Temperature: $-20^{\circ}\text{C} \sim +180^{\circ}\text{C}$

Applicable media: Hot oil, some chemical products, good oxidation resistance.

Bolts/Nuts:

ANSI Heavy Hex Nut



1. Material: SAE J995 2.
2. Thread: ANSI B 1.1-1982, class 2B.
3. Surface Treatment: Zinc electroplated per ASTM B633 CLASS FE/ZN5 TYPE III , thickness $\geq 5\mu\text{m}$ per class SC1.

Metric Heavy Hex Nut

1. Material: ISO 898-2:1992 \ GB/T3098.2-2000 Class 8.
2. Thread: ISO 261, tolerance 6h for M10& M12, 7h for M16 and above.
3. Surface Treatment: Zinc Electroplated followed by a yellow chromatedip per ISO 2081 FE/ZN5, ISO4520 CLASS 1A.

ANSI Oval Neck Track Bolt

1. Material: SAE J429 5.
2. Thread: UNC thread per ANSI B 1.1 Class 2A.
3. Surface Treatment: Silver chromate electroplated per ASTM B633 CLASS FE/ZN5 TYPE III, thickness $\geq 5\mu\text{m}$ per class SC1.

Metric Oval Neck Track Bolt

1. Material: ISO 898-1: 1992 \ GB/T3098.1-2000 Class 8.8.
2. Thread: ISO metric thread per ISO 261, tolerance 6h.
3. Surface Treatment: Yellow chromate electroplated per ISO 2081 FE/ZN5 ISO4520 CLASS 1A.

4.0 DIMENSIONS AND PERFORMANCE

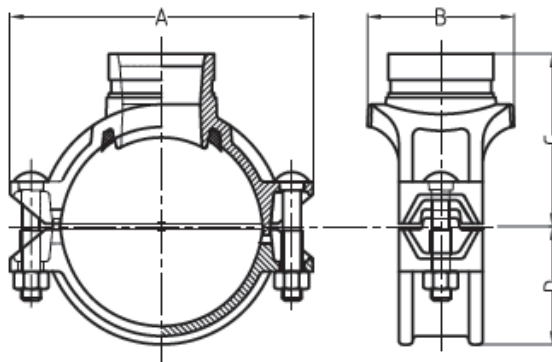



Nominal Size	Pipe O.D	Working Pressure	Hole Dia. mm/in	Dimensions				Bolt Size
				A	B	C	D	
mm/in	mm/in	PSI/Mpa	+1.6,0/+0.063,0	mm/in	mm/in	mm/in	mm/in	mm/in
50x32 2x1¼	60.3x42.4 2.375x1.660	300 2.07	45 1.75	116 4.57	76 2.99	69.5 2.74	39 1.54	3/8x55 M10X57
50x40 2x1½	60.3x48.3 2.375x1.900	300 2.07	45 1.75	116 4.57	76 2.99	69.5 2.74	39 1.54	3/8x55 M10X57
65x25 2½x1	73.0x33.7 2.875x1.315	300 2.07	38 1.5	137 5.39	71 2.8	78 3.07	49 1.93	1/2x70 M12X70
65x32 2½x1¼	73.0x42.4 2.875x1.660	300 2.07	51 2	137 5.39	84.5 3.33	78 3.07	49 1.93	1/2x70 M12X70
65x40 2½x1½	73.0x48.3 2.875x1.900	300 2.07	51 2	137 5.39	84.5 3.33	78 3.07	49 1.93	1/2x70 M12X70
65x25 76.1x1	76.1x33.7 3.000x1.315	300 2.07	38 1.5	137 5.39	71 2.8	78 3.07	49.5 1.95	1/2x70 M12X70
65x32 76.1x1¼	76.1x42.4 3.000x1.660	300 2.07	51 2	137 5.39	84.5 3.33	78 3.07	49.5 1.95	1/2x70 M12X70
65x40 76.1x1½	76.1x48.3 3.000x1.900	300 2.07	51 2	137 5.39	84.5 3.33	78 3.07	49.5 1.95	1/2x70 M12X70
80x25 3x1	88.9x33.7 3.500x1.315	300 2.07	38 1.5	152 5.98	72.5 2.85	84.5 3.33	56.5 2.22	1/2x75 M12X76
80x32 3x1¼	88.9x42.4 3.500x1.660	300 2.07	51 2	152 5.98	85.5 3.37	84.5 3.33	56.5 2.22	1/2x75 M12X76
80x40 3x1½	88.9x48.3 3.500x1.900	300 2.07	51 2	152 5.98	85.5 3.37	84.5 3.33	56.5 2.22	1/2x75 M12X76
80x50 3x2	88.9x60.3 3.500x2.375	300 2.07	64 2.5	152 5.98	98 3.86	84.5 3.33	56.5 2.22	1/2x75 M12X76
100x25 4x1	114.3x33.7 4.500x1.315	300 2.07	38 1.5	188 7.4	78.4 3.09	102 4.02	70 2.76	1/2x75 M12X76
100x32 4x1¼	114.3x42.4 4.500x1.660	300 2.07	51 2	188 7.4	89 3.5	102 4.02	70 2.76	1/2x75 M12X76
100x40 4x1½	114.3x48.3 4.500x1.900	300 2.07	51 2	188 7.4	89 3.5	102 4.02	70 2.76	1/2x75 M12X76
100x50 4x2	114.3x60.3 4.500x2.375	300 2.07	64 2.5	188 7.4	104.5 4.11	102 4.02	70 2.76	1/2x75 M12X76



Nominal Size	Pipe O.D	Working Pressure	Hole Dia mm/in	Dimensions				Bolt Size
				A	B	C	D	
mm/in	mm/in	PSI/Mpa	+1.6,0/+0.063,0	mm/in	mm/in	mm/in	mm/in	mm/in
100x65 4x2½	114.3x73.0 4.500x2.875	300 2.07	70 2.75	188 7.4	104.5 4.11	102 4.02	70 2.76	1/2x75 M12X76
100x65 4x76.1	114.3x76.1 4.500x3.000	300 2.07	70 2.75	188 7.4	104.5 4.11	102 4.02	70 2.76	1/2x75 M12X76
100x80 4x3	114.3x88.9 4.500x3.500	300 2.07	89 3.5	188 7.4	128 5.03	102 4.02	70 2.76	1/2x75 M12X76
125x32 139.7x1¼	139.7x42.4 5.500x1.660	300 2.07	51 2	221.5 8.72	95 3.74	118 4.65	84 3.31	5/8x85 M16X85
125x40 139.7x1½	139.7x48.3 5.500x1.900	300 2.07	51 2	221.5 8.72	95 3.74	118 4.65	84 3.31	5/8x85 M16X85
125x50 139.7x2	139.7x60.3 5.500x2.375	300 2.07	64 2.5	221.5 8.72	112.5 4.43	118 4.65	84 3.31	5/8x85 M16X85
125x65 139.7x76.1	139.7x76.1 5.500x3.000	300 2.07	70 2.75	221.5 8.72	112.5 4.43	118 4.65	84 3.31	5/8x85 M16X85
125x80 139.7x3	139.7x88.9 5.500x3.500	300 2.07	89 3.5	221.5 8.72	132 5.2	118 4.65	84 3.31	5/8x85 M16X85
125x100 139.7x4	139.7x114.3 5.500x4.500	300 2.07	114 4.5	221.5 8.72	160 6.3	125 4.92	84 3.31	5/8x85 M16X85
150x50 159.0x2	159.1x60.3 6.250x2.375	300 2.07	64 2.5	244 9.6	112.5 4.43	125 4.92	94 3.7	5/8x105 M16X108
150x100 159.0x108.0	159.1x108.0 6.250x4.250	300 2.07	114 4.5	244 9.6	154 6.06	133 5.24	94 3.7	5/8x105 M16X108
150x100 159.0x4	159.1x114.3 6.250x4.500	300 2.07	114 4.5	244 9.6	159 6.26	125 4.92	94 3.7	5/8x105 M16X108
150x50 165.1x2	165.1x60.3 6.500x2.375	300 2.07	64 2.5	244 9.6	112.5 4.43	127 5	97.5 3.84	5/8x105 M16X108
150x65 165.1x76.1	165.1x76.1 6.500x3.000	300 2.07	70 2.75	244 9.6	112.5 4.43	130 5.12	97.5 3.84	5/8x105 M16X108



Nominal Size	Pipe O.D	Working Pressure	Hole Dia mm/in	Dimensions				Bolt Size
				A	B	C	D	
mm/in	mm/in	PSI/Mpa	+1.6,0/+0.063,0	mm/in	mm/in	mm/in	mm/in	mm/in
150x80 6½O.Dx3	165.1x88.9 6.500x3.500	300 2.07	89 3.5	244 9.6	132 5.2	130 5.12	97.5 3.84	5/8x105 M16X108
150x100 6½O.Dx4	165.1x114.3 6.500x4.500	300 2.07	114 4.5	244 9.6	154 6.06	135 5.32	97.5 3.84	5/8x105 M16X108
150x40 6x1½	168.3x48.3 6.500x1.900	300 2.07	51 2	247 9.72	95 3.74	128 5.04	98.5 3.88	5/8x105 M16X108
150x50 6x2	168.3x60.3 6.625x2.375	300 2.07	64 2.5	247 9.72	114 4.49	134 5.28	98.5 3.88	5/8x105 M16X108
150x65 6x2½	168.3x73.0 6.625x2.875	300 2.07	70 2.75	247 9.72	112.5 4.43	135 5.32	98.5 3.88	5/8x105 M16X108
150x65 6x2½	168.3x76.1 6.625x3.000	300 2.07	70 2.75	247 9.72	112.5 4.43	135 5.32	98.5 3.88	5/8x105 M16X108
150x80 6x3	168.3x88.9 6.625x3.500	300 2.07	89 3.5	247 9.72	132 5.2	136.5 5.37	98.5 3.88	5/8x105 M16X108
150x100 6x4	168.3x114.3 6.625x4.500	300 2.07	114 4.5	247 9.72	160 6.3	138 5.43	98.5 3.88	5/8x105 M16X108
200x50 8x2	219.1x60.3 8.625x2.375	300 2.07	64 2.5	320 12.6	118 4.65	158 6.22	125 4.92	3/4x115 M20X115
200x65 8x76.1	216.3x76.1 8.516x3.000	300 2.07	70 2.75	315 12.4	117 4.61	157 6.18	122 4.8	3/4x115 M20X115
200x65 8x2½	219.1x73.0 8.625x2.875	300 2.07	70 2.75	320 12.6	118 4.65	158 6.22	125 4.92	3/4x115 M20X115
200x65 8x76.1	219.1x76.1 8.625x3.000	300 2.07	70 2.75	320 12.6	118 4.65	158 6.22	125 4.92	3/4x115 M20X115
200x80 8x3	219.1x88.9 8.625x3.500	300 2.07	89 3.5	320 12.6	136.5 5.37	161 6.34	125 4.92	3/4x115 M20X115
200x100 8x4	219.1x108.0 8.625x4.250	300 2.07	114 4.5	320 12.6	162 6.38	161 6.34	125 4.92	3/4x115 M20X115



Nominal Size	Pipe O.D	Working Pressure	Hole Dia mm/in	Dimensions				Bolt Size
				A	B	C	D	
mm/in	mm/in	PSI/Mpa	+1.6,0/+0.063,0	mm/in	mm/in	mm/in	mm/in	mm/in
200x100 8x4	219.1x114.3 8.625x4.500	300 2.07	114 4.5	320 12.6	162 6.38	161 6.34	125 4.92	3/4x115 M20X115
250x65 10x2½	273.0x76.1 10.75x3.000	300 2.07	70 2.75	376 14.8	118 4.65	189 7.44	155 6.1	3/4x120 M20X115
250x80 10x3	273.0x88.9 10.75x3.500	300 2.07	89 3.5	376 14.8	136.5 5.37	189 7.44	155 6.1	3/4x120 M20X115
250x100 10x4	273.0x108 10.75x4.250	300 2.07	114 4.5	376 14.8	164 6.46	189 7.44	155 6.1	3/4x120 M20X115
250x100 10x4	273.0x114.3 10.75x4.500	300 2.07	114 4.5	376 14.8	164 6.46	189 7.44	155 6.1	3/4x120 M20X115

5.0 REFERENCE MATERIALS

Approved certification for grooved fittings and couplings

I-JM-Grooved fitting: Installation Instructions for grooved fittings and couplings