

AWWA C515 FLANGED RESILIENT OS&Y GATE VALVE FOR FIRE-PROTECTION SYSTEM

Type: XZ41X

Doc No: DS-901-XZ41X-01-E-X

1.0 PRODUCT OVERVIEW

The AWWA C515 OS&Y gate valve is mainly used to connect and cut off the medium in the pipeline. The stem nut is on the bracket. When opening and closing the gate plate, the rotary stem nut is used to realize the rise and fall of the stem. The valve switch can be identified according to the lifting height of the stem.



Dimensions:

2" (DN50)-24" (DN600)

Design Standard:

AWWA C515、ASME B16.10

Connection Standard:

ASME B16.1 CL 125

Working Pressure:

300PSI, 250PSI, 200PSI

Application:

The AWWA C515 OS&Y gate valve is applied at the fire-protection system, the working temperature is 0°C-80°C.

Material of Matching Products:

Connect flanged pipes in accordance with American Standard ASME B16.1 CL125

Surface Treatment:

- Epoxy power painting (color numbers as RAL3000, RAL3001、RAL3000-1, RAL3009、RAL3011、RAL3016、RAL3020、RAL8024,etc)
- Painting (color numbers as RAL3000,etc)
- Others would be available upon clients' detailed request

2.0 APPROVALS



3.0 SPECIFICATIONS

Product Sketch:

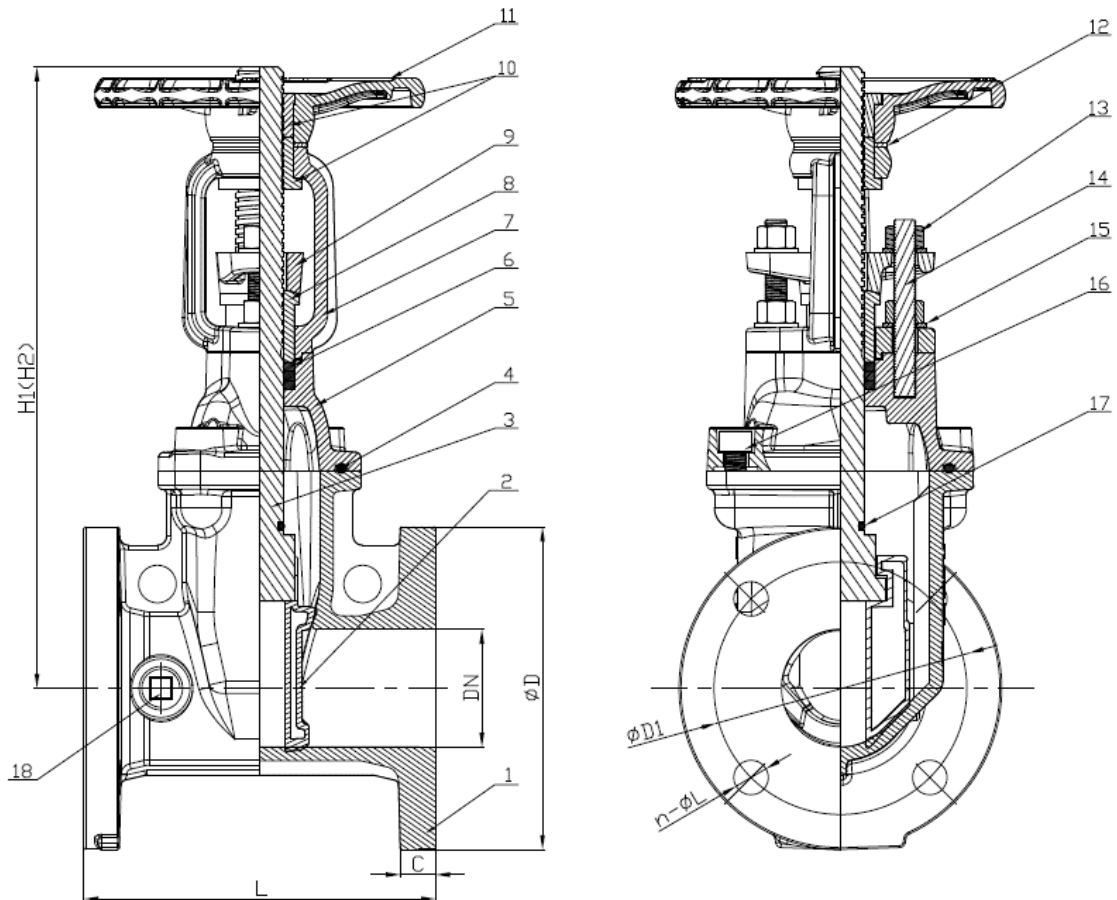

Part No.	Part	Standard Specification	Options
1	Valve Body	ASTM A536,65-45-12	
2	Resilient Wedge disc	ASTM A536,65-45-12+EPDM	
3	Stem	AISI 420	AISI 304、AISI 316、AISI 431
4	Bonnet Gasket	EPDM	
5	Bonnet	ASTM A536,65-45-12	
6	Sealing Packing	EPDM	
7	Yoke	EN-GJS-450-10	
8	Stem Bushing	Brass HPb59-1	
9	Gland	EN-GJS-450-10	
10	Stem Nut	Brass HPb59-1	Bronze ZQSN5-5-5
11	Handwheel	EN-GJS-450-10	
12	Washer	Brass HPb59-1	
13	Gland Nut	Carbon Steel Zinc Plated	AISI 304、AISI 316、

14	Stud	Carbon Steel Zinc Plated	AISI 304、AISI 316、
15	Flat Washer	Carbon Steel Zinc Plated	AISI 304、AISI 316、
16	Nut	Carbon Steel Zinc Plated	AISI 304、AISI 316、
17	O-Ring	EPDM	NBR
18	NPT Pipe Plug	ASTM B62 C83600	

4.0 DIMENSIONS AND PERFORMANCE

4.1 Dimensions

DN		Dimensions (mm)						
Inch	mm	L	H1 (Close)	H2 (Open)	D	D1	C	n-∅L
2"	50	178	348	400	152	120.7	16	4-Φ19.1
2.5"	65	190	373	440	178	139.7	17.5	4-Φ19.1
3"	80	203	408	490	191	152.4	19.1	4-Φ19.1
4"	100	229	471	573	229	190.5	19.1	8-Φ19.1
5"	125	254	541	665	254	215.9	19.1	8-Φ22.2
6"	150	267	601	755	279	241.3	19.1	8-Φ22.2
8"	200	292	720	920	343	298.5	22.2	8-Φ22.2
10"	250	330	939	1193	406	362	23.8	12-Φ25.4
12"	300	356	1065	1370	483	431.8	25.4	12-Φ25.4
14"	350	381	1210	1560	533	476.3	25.4	12-Φ28.6
16"	400	406	1280	1680	597	539.8	25.4	16-Φ28.6
18"	450	432	1760	2210	635	577.9	25.4	16-Φ31.8
20"	500	457	1780	2280	699	635	28.6	20-Φ31.8
24"	600	508	1950	2550	813	749.3	30.1	20-Φ34.9

4.2 Flow loss rates

DN	DN50	DN65	DN80	DN100	DN125	DN150	DN200
Kv	40.7	64.6	94	162.8	254.4	366.3	651.1
DN	DN250	DN300	DN350	DN400	DN450	DN500	DN600
Kv	1017.4	1456	1837.7	2437.9	3122.8	3876.5	5666.3

5.0 REFERENCE MATERIALS

Approved certification for Gate Valve