

AWWA C515 FLANGED RESILIENT NRS GATE VALVE

FOR FIRE PROTECTION

Type: Z45X

Doc No: DS-901-Z45X-01-E-X

1.0 PRODUCT OVERVIEW

The valve is mainly used to connect and cut off the medium in the pipeline by rotating the stem. Its transmission thread is inside the body cavity, which can save installation space.



Dimensions:

2"(DN50)-24"(DN600)

Design Standard:

AWWA C515、ASME B16.10

Connection Standard:

ASME B16.1 CL 125

Working Pressure:

300PSI, 250PSI, 200PSI

Application:

This American standard flanged NRS gate valve is applied at the fire-protection system, the working temperature is 0°C-80°C.

Material of Matching Products:

Flanged pipes in accordance with American Standard ASME B16.1 CL125

Surface Treatment:

- Epoxy power painting (color numbers as RAL3000, RAL3001, RAL3016, etc)
- Painting (color numbers as RAL3000, RAL3001, etc)
- Others would be available upon clients' detailed request

2.0 APPROVALS



, CRN 0C3073.7

3.0 SPECIFICATIONS

Product Sketch:

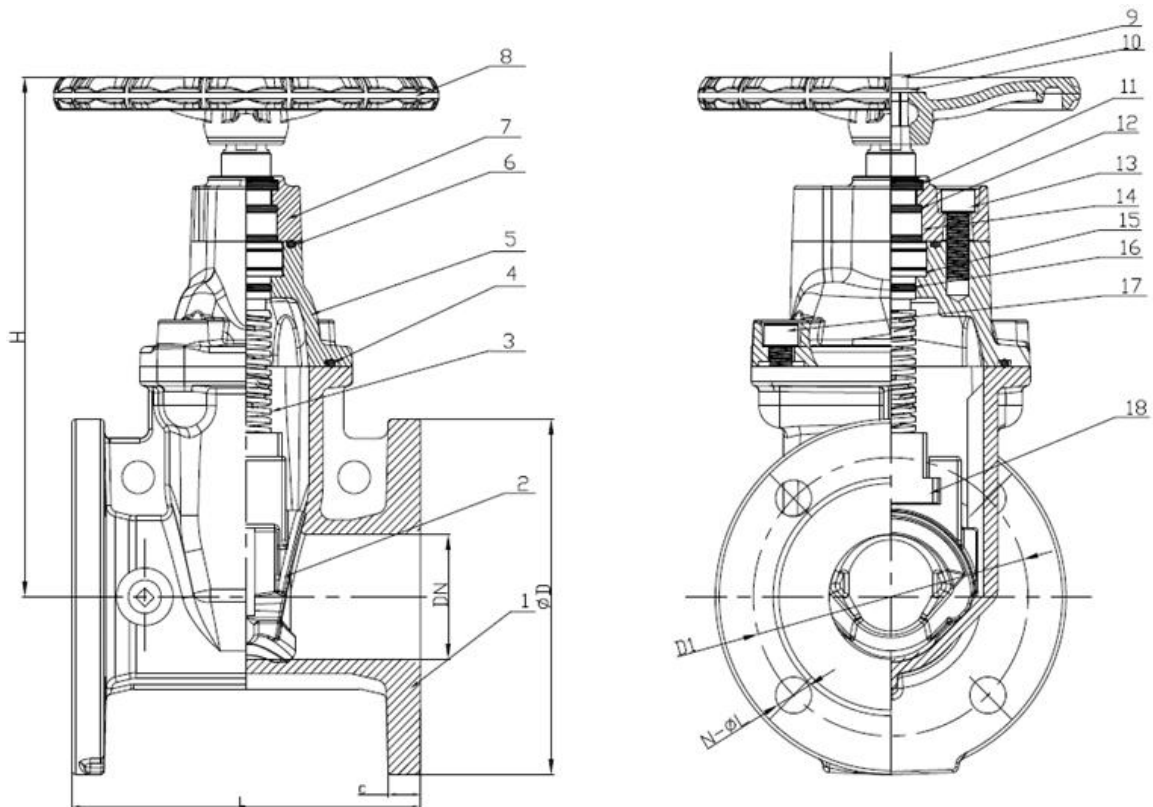

Part No.	Part	Standard Specification	Options
1	Valve Body	ASTM A536,65-45-12	
2	Resilient Wedge disc	ASTM A536,65-45-12+EPDM	
3	Stem	AISI 420	AISI 304, AISI 316, AISI 431
4	Bonnet Gasket	EPDM	
5	Bonnet	ASTM A536,65-45-12	
6	O-Ring	NBR	EPDM
7	Gland	ASTM A536,65-45-12	
8	Handwheel	ASTM A536,65-45-12	
9	Bolt	Carbon Steel Zinc Plated	AISI 304, AISI 316
10	Flat Washer	Carbon Steel Zinc Plated	AISI 304, AISI 316
11	Ring Wiper	EPDM	NBR
12	O-Ring	NBR	EPDM
13	Bolt	Carbon Steel Zinc Plated	AISI 304, AISI 316
14	Axis guide	Brass HPb59-1	
15	Washer	Brass HPb59-1	
16	O-Ring	NBR	EPDM
17	Bolt	Carbon Steel Zinc Plated	AISI 304, AISI 316
18	Wedge nut	Brass HPb59-1	

4.0 DIMENSIONS AND PERFORMANCE

4.1 Dimensions

DN		Dimensions (mm)					
Inch	mm	L	H	D	D1	C	n-ØL
2"	50	178	254	152	120.7	16	4-Φ19.1
2.5"	65	190	275	178	139.7	17.5	4-Φ19.1
3"	80	203	301	191	152.4	19.1	4-Φ19.1
4"	100	229	355	229	190.5	19.1	8-Φ19.1
5"	125	254	393	254	215.9	19.1	8-Φ22.2
6"	150	267	448	279	241.3	19.1	8-Φ22.2
8"	200	292	548	343	298.5	22.2	8-Φ22.2
10"	250	330	626	406	362	23.8	12-Φ25.4
12"	300	356	722	483	431.8	25.4	12-Φ25.4
14"	350	381	918	533	476.3	25.4	12-Φ28.6
16"	400	406	918	597	539.8	25.4	16-Φ28.6
18"	450	432	1108	635	577.9	25.4	16-Φ31.8
20"	500	457	1130	699	635	28.6	20-Φ31.8
24"	600	508	1311	813	749.3	30.1	20-Φ34.9

4.2 Flow rates

DN	DN50	DN65	DN80	DN100	DN125	DN150	DN200
Kv Value	41	65	94	163	254	366	651
DN	DN250	DN300	DN350	DN400	DN450	DN500	DN600
Kv Value	1017	1456	1838	2438	3123	3877	5666

5.0 REFERENCE MATERIALS

Approved certification for Gate Valve